

VTBU AD 2.1 AERODROME LOCATION INDICATOR AND NAME

VTBU - RAYONG / U-TAPAO RAYONG PATTAYA INTERNATIONAL AIRPORT

VTBU AD 2.2 AERODROME GEOGRAPHICAL AND ADMINISTRATIVE DATA

1	ARP coordinates and site at AD	124046.6N 1010017.7E Centre of the runway, 1752.5 M from THR RWY18
2	Direction and distance from (city)	34 KM W of Rayong
3	Elevation/Reference temperature	18 M (59 FT) / 34°C
4	Geoid Undulation at AD ELEV PSN	NIL
5	MAG VAR/Annual change	0.55°W (2016) / 0.00°E
6	AD Administration, address, telephone, telefax, telex, AFS	Military: Base Operations Division Naval Air Station Royal Thai Naval Air Division 70 moo.2 Phala Banchang Rayong 21130 Thailand Tel: +663 824 5193 (Dispatcher) +663 824 5190, +668 8669 9221 (TWR) +663 824 5196 (APP) Fax: +663 824 5193 (Dispatcher) Civil: U-Tapao Airport Authority U-Tapao Rayong Pattaya International Airport 700 moo.2 Phala Banchang Rayong 21130 Thailand Tel: +663 824 5600 (Airport Authority) Fax: +663 824 5600 (Airport Authority) AFS: VTBUZPZX
7	Types of traffic permitted (IFR/VFR)	IFR/VFR
8	Remarks	Operator: Royal Thai Navy

VTBU AD 2.3 OPERATIONAL HOURS

1	Aerodrome Operator	H24
2	Customs and immigration	H24
3	Health and sanitation	H24
4	AIS Briefing Office	H24
5	ATS Reporting Office (ARO)	H24
6	MET Briefing Office	H24
7	ATS	H24
8	Fuelling	H24
9	Handling	H24
10	Security	H24
11	De-icing	NIL
12	Remarks	NIL

VTBU AD 2.4 HANDLING SERVICES AND FACILITIES

1	Cargo-handling facilities	Handling weights up to 3 T
2	Fuel/oil types	Jet A-1, AVGAS, JP8
3	Fuelling facilities/capacity	1 JET A-1 Refueller @ 40,000 L 2 JET A-1 Refueller @ 12,000 L 1 Hydrant Dispenser for JET A-1 1 JET A-1 Refueller @ 45,000 L 1 JET A-1 Refueller @ 12,000 L 3 Hydrant Cart for JP-8 1 AVGAS DC Motor dispenser from drum 200 L
4	De-icing facilities	NIL
5	Hangar space for visiting aircraft	NIL
6	Repair facilities for visiting aircraft	NIL
7	Remarks	NIL

VTBU AD 2.5 PASSENGER FACILITIES

1	Hotels	5 KM from AD and in the city
2	Restaurants	In Pattaya city and Banchang
3	Transportation	Airport buses and limousines
4	Medical facilities	First aid station and queen Sirikit Hospital in the AD
5	Bank and Post Office	2 KM from AD
6	Tourist Office	In Pattaya city
7	Remarks	NIL

VTBU AD 2.6 RESCUE AND FIRE FIGHTING SERVICES

1	AD category for fire fighting	24 HR: Category 10
2	Rescue equipment	2 boats of 10 people, Rescue truck, Ambulance
3	Capability for removal of disabled aircraft	Available up to A320
4	Remarks	U-Tapao Airport Authority Tel: +669 7326 6074

VTBU AD 2.7 SEASONAL AVAILABILITY - CLEARING

1	Types of clearing equipment	NIL
2	Clearance priorities	NIL
3	Remarks	The aerodrome is available all seasons.

VTBU AD 2.8 APRONS, TAXIWAYS AND CHECK LOCATIONS/POSITIONS DATA

1	Apron surface and strength	Apron A and B Surface: Concrete Strength: PCN 39/R/B/X/T Apron C Surface: Concrete Strength: PCN 40/R/B/X/T Apron D Surface: Concrete Strength: PCN 77/R/B/X/T
2	Taxiway width, surface and strength	Width: 23 M Surface: Concrete and asphalt Strength: TWY A, B, C, D, E, F, G, H: PCN 65/R/B/W/T TWY I: PCN 9/R/B/W/T
3	Altimeter checkpoint location and elevation	Location at Apron Elevation 18 M (59 FT)
4	VOR checkpoints	NIL
5	INS checkpoints	NIL
6	Remarks	NIL

VTBU AD 2.9 SURFACE MOVEMENT GUIDANCE AND CONTROL SYSTEM AND MARKINGS

1	Use of aircraft stand ID signs, TWY guide lines and visual docking/parking guidance system of aircraft stands	Taxi guidance signs, all RWY and TWY intersections and holding positions.
2	RWY and TWY markings and LGT	RWY marking: RWY Designation, THR, TDZ, CL, Aiming Point and Edge RWY LGT: THR, RWY Edge and RWY End TWY marking: NIL TWY LGT: TWY Edge
3	Stop bars	NIL
4	Remarks	NIL

VTBU AD 2.10 AERODROME OBSTACLES

In approach/TKOF areas			In circling areas and at AD		Remarks
1			2		
RWY/Area affected	Obstacle type Elevation Markings/LGT	Coordinates	Obstacle type Elevation Markings/LGT	Coordinates	3
a	b	c	a	b	
RWY 18 Left base	Hill 2.2 NM NNE, 896 FT. from VOR no marking/LGT	NIL	NIL	NIL	NIL
High tension line distance 840 M. from RWY THR 18, elevation of the high tension line 18 M.					

VTBU AD 2.11 METEOROLOGICAL INFORMATION PROVIDED

1	Associated MET Office	Aeronautical Meteorology Subsection Base Operation Section Naval Air Station Subdivision Royal Thai Naval Air Division
2	Hours of service MET Office outside hours	H24 NIL
3	Office responsible for TAF preparation Periods of validity	Aeronautical Meteorology Subsection 24 HR
4	Type of landing forecast Interval of issuance	TREND 30 Min
5	Briefing/consultation provided	Personal Consultation Tel: +663 824 5489 E-mail: weather.utapao@gmail.com
6	Flight documentation Language(s) used	Charts, Tabular Forms and Abbreviated Plain Language Texts English
7	Charts and other information available for briefing or consultation	S, U85, U70, U50, U40, U30, U25, U20, SWH, SWM, SWL, P85, P70, P50, P40, P30, P25, P20, P15, satellite and radar pictures
8	Supplementary equipment available for providing information	NIL
9	ATS units provided with information	U-Tapao TWR U-Tapao APP
10	Additional information (limitation of service, etc.)	NIL

VTBU AD 2.12 RUNWAY PHYSICAL CHARACTERISTICS

Designations RWY NR	TRUE BRG	Dimensions of RWY(M)	Strength (PCN) and surface of RWY and SWY	THR coordinates RWY end coordinates THR geoid undulation	THR elevation and highest elevation of TDZ of precision APP RWY
1	2	3	4	5	6
18	184°(MAG)	3505x60	PCN 59/F/B/X/T Concrete and asphalt	124144.26N 1010022.66E	THR 18 M (59 FT)
36	004°(MAG)	3505x60	PCN 59/F/B/X/T Concrete and asphalt	123950.42N 1010013.26E	THR 7.6 M (24 FT)

Slope of RWY-SWY	SWY dimensions (M)	CWY dimensions (M)	Strip dimensions (M)	OFZ	Remarks
7	8	9	10	11	12
0.3%	305x60	305x300	4235x300	NIL	NIL
-0.3%	305x60	305x300	4235x300	NIL	NIL

VTBU AD 2.13 DECLARED DISTANCES

RWY Designator	TORA (M)	TODA (M)	ASDA (M)	LDA (M)	Remarks
1	2	3	4	5	6
18	3505	3810	3810	3505	NIL
36	3505	3810	3810	3505	NIL

VTBU AD 2.14 APPROACH AND RUNWAY LIGHTING

RWY Designator	APCH LGT type LEN INTST	THR LGT colour WBAR	VASIS (MEHT) PAPI	TDZ, LGT LEN	RWY Centre Line LGT Length, spacing, colour, INTST	RWY edge LGT LEN, spacing, colour INTST	RWY End LGT colour WBAR	SWY LGT LEN (M) colour	Remarks
1	2	3	4	5	6	7	8	9	10
18	CAT1 (570 M)	Green	PAPI BI-Lateral 3°	NIL	NIL	3505 M 60 M White LIH	Red	NIL	NIL
36	SALS	Green	PAPI Left 3°	NIL	NIL	3505 M 60 M LIH	Red	NIL	NIL

VTBU AD 2.15 OTHER LIGHTING, SECONDARY POWER SUPPLY

1	ABN/IBN location, characteristics and hours of operation	ABN: On top of control tower, FLG WG EV 2 SEC. Sunset to sunrise and daylight when low visibility. IBN: NIL
2	LDI location and LGT Anemometer location and LGT	WDI - 1 WDI left side of THR RWY 36 (500 M from RWY THR) - 1 WDI right side of THR RWY 18 (500 M from RWY THR)
3	TWY edge and centre line lighting	TWY edge lights (blue)
4	Secondary power supply/switch-over time	Secondary power supply to all lighting at RWY 18/36 Switch-over time: 0 SEC
5	Remarks	NIL

VTBU AD 2.16 HELICOPTER LANDING AREA

1	Coordinates TLOF or THR of FATO Geoid undulation	NIL
2	TLOF and/or FATO elevation M/FT	NIL
3	TLOF and FATO area dimensions, surface, strength, marking	NIL
4	True and MAG BRG of FATO	NIL
5	Declared distance available	NIL
6	APP and FATO lighting	NIL
7	Remarks	Landing on TWY E.

VTBU AD 2.17 ATS AIRSPACE

1	Designation and lateral limits	A circle of 5 NM radius centred on 1240.7N 10100.5E
2	Vertical limits	up to but not including 2000 FT/AGL
3	Airspace classification	C
4	ATS unit call sign Language(s)	U-Tapao Tower English, Thai
5	Transition altitude	11000 FT
6	Remarks	NIL

VTBU AD 2.18 ATS COMMUNICATION FACILITIES

Service designation	Call sign	Frequency	Hours of operation	Remarks
1	2	3	4	5
APP	U-Tapao Approach	119.7 MHZ 121.5 MHZ ¹⁾ 134.5 MHZ 238.3 MHZ 273.3 MHZ 243.0 MHZ ¹⁾	H24	RTN ¹⁾ Emergency frequency
TWR	U-Tapao Tower	118.1 MHZ 118.3 MHZ 121.5 MHZ ¹⁾ 227.0 MHZ 243.0 MHZ ¹⁾	H24	
GND	U-Tapao Ground	121.9 MHZ 275.8 MHZ	H24	
ATIS		127.2 MHZ	H24	

VTBU AD 2.19 RADIO NAVIGATION AND LANDING AIDS

Type of aid, MAG VAR CAT of ILS/MLS (For VOR/ILS/MLS, give declination)	ID	Frequency	Hours of operation	Position of transmitting antenna coordinates	Elevation of DME transmitting antenna	Remarks
1	2	3	4	5	6	7
NDB	UP	414 KHZ	H24	123943.02N 1005941.96E		
DVOR/DME	BUT	110.8 MHZ CH 45X	H24	124000.02N 1010001.71E	6 M / AGL	DVOR/DME restriction due to mountainous terrain surround DVOR/DME station, coverage check does not provide adequate signal clockwise orbit 40 NM at required altitude and distance in various areas: <ul style="list-style-type: none"> - Radial 101°-170° altitude should not below 2 000 FT - Radial 171°-250° altitude should not below 6 000 FT - Radial 251°-320° altitude should not below 8 000 FT - Radial 321°-050° altitude should not below 8 000 FT - Radial 051°-100° altitude should not below 4 000 FT

Type of aid, MAG VAR CAT of ILS/MLS (For VOR/ILS/ MLS, give declination)	ID	Frequency	Hours of operation	Position of transmitting antenna coordinates	Elevation of DME transmitting antenna	Remarks
1	2	3	4	5	6	7
ILS CAT I LOC/DME RWY 18	IBUT	111.1 MHZ CH 48X	H24	123936.66N 1010012.13E	5 M / AGL	A. The Cat I ILS/DME installed at U-Tapao Rayong Pattaya International Airport for RWY18. There is no back course. The localize aerial array is located on the extended runway centre line at distance of 420 M (1377.9 FT) from the threshold of RWY 36. The antenna array 1.30 M (4.3 FT) high is installed on top of wooden platform 3.6 M (11.8 FT) high above ground, with an aperture of 40.3 M (132.2 FT). B. DME paired with LOC. frequency omnidirectional, low power (100 watts). C. Glide Path 3° above the horizontal, paired with localizer frequency. The 15 M (49.2 FT) glide path aerial mast is offset 120 M(393.7 FT) to the east side of runway centre line and from threshold of RWY18, 371 M (1217 FT). D. Middle Marker 1050 M (3445 FT) from threshold of RWY18 along extended runway centre line.
GP		331.7 MHZ	H24	124130.31N 1010025.52E		
MM		75 MHZ		1242.1N 101 00.0E		
Compass Locator	UT	234 KHZ	H24	1242.1N 101 00.0E		
TACAN	BUT	CH 105	2300-1100	1240.5N 101 00.4E		Military Facilities 30 min PN to ATC.

VTBU AD 2.20 LOCAL AERODROME REGULATIONS

1. VFR FLIGHT IN U-TAPAO TERMINAL CONTROL AREA/ CONTROL ZONE

1.1 BY DAY (Sunrise/Sunset)

1.1.1 Unless otherwise specifically authorized, VFR flights shall not be Permitted to land / take-off at Rayong/U-Tapao Rayong Pattaya International Airport when conditions as reported to U-Tapao APP/TWR, by an authorized ground observer are less than

Ground Visibility	- 5 KM; or
Ceiling	- 450 M (1 500 FT)

1.1.2 Authorization may be granted by ATC for special VFR flights (1.4) to land / take-off at Rayong/U-Tapao Rayong Pattaya International Airport under conditions less than 1.1.1 above but not less than

Ground Visibility	- 1 500 M
-------------------	-----------

1.1.3 As reported to U-Tapao APP/TWR, by an authorized ground observer.

1.2 BY NIGHT (Sunrise/Sunset)

1.2.1 VFR flights to land/take-off at Rayong/U-Tapao Rayong Pattaya International Airport shall not be permitted to operate between sunset and sunrise, or such other period between sunset and sunrise as may be prescribed by U-Tapao APP/TWR.

1.3 AT ALL TIME as authorized

1.3.1 VFR flights within the U-TAPAO TMA/ CTR shall be conducted so that the aircraft maintain flight visibility and distance from cloud equal to or greater than those specified in ICAO Annex 2, Chapter 4 Table 4-1, viz:

- Flight Visibility
-8 KM at and above 3 050 M (10 000 FT) AMSL
-5 KM below 3 050 M (10 000 FT) AMSL
- Distance from cloud
-1500 M horizontally and 300 M (1 000 FT) vertically

1.4 SPECIAL VFR FLIGHTS may be permitted when ground visibility is not less than 1500 M, provided that the aircraft is equipped with functioning radio receiver and the pilot has agreed to guard on the appropriate ATC communication frequency. ATC shall effect IFR separation between all special VFR flights and between such flights and IFR flights.

2. VFR DEPARTURE PROCEDURES

2.1 After take-off, aircraft shall continue climbing straight ahead until passing the departure end of runway unless safety dictates otherwise or when specifically authorized by the tower.

3. U-TAPAO VFR LOCAL PROCEDURES

3.1 Aerodrome Traffic Pattern

Traffic pattern shown in diagram. The unlighted 896 FT hill, 2.2 NM NNE of U-Tapao constitutes a hazard to VFR operation:

3.1.1 Rectangular

- Altitude 1 400 FT MSL
- Left traffic for runway 18
- Right traffic for runway 36
- Enter downwind leg at a 45°.

3.1.2 Overhead approach

- Altitude 1 900 FT MSL
- Runway 18 left turns
- Runway 36 right turns
- Enter final at a 45°.

3.1.3 Helicopter

- Altitude 800 FT MSL
- Right traffic for runway 18
- Left traffic for runway 36
- Landing on parallel taxiway
- Enter parallel taxiway at a 45°.

3.2 VFR Departure Procedures

3.2.1 After taking off aircraft shall continue climbing straight ahead until passing the departure end of runway unless safety dictates otherwise or when specifically authorized by the tower.

VFR TRAFFIC PATTERNS FIELD ELEVATION 59 FT

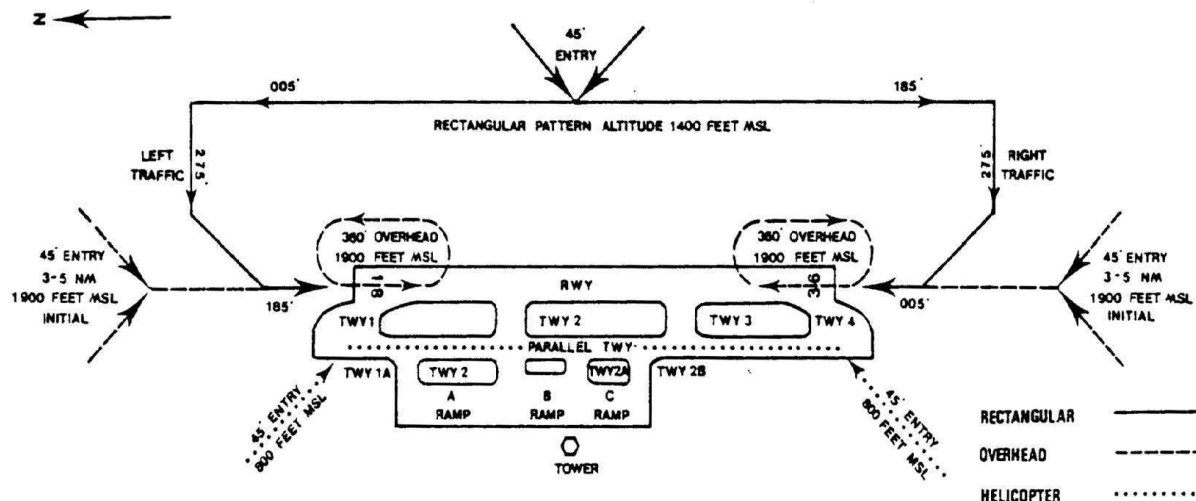

4. RADIO COMMUNICATIONS FAILURE

4.1 Departing Aircraft

4.1.1 Aircraft shall not be permitted to take-off unless two-way radio communication can be maintained with the control tower.

4.1.2 If an aircraft experiences radio communications failure after departure, the pilot shall comply with the VFR cruising altitude.

4.2 Arriving Aircraft

4.2.1 When aircraft radio receiver inoperative, report their position, distance, heading, altitude and departure point when approaching 50NM from U-Tapao Rayong Pattaya International Airport by transmitting in the blind.

4.2.2 When two-way communications failure, radio transmitter or receiver inoperative, observe the direction of traffic in the pattern, and enter downwind with the flow of traffic.

4.2.2.1 Day time

- Joining the traffic pattern of the landing runway be conformed to the altitude for the type of aircraft as listed in item 3, then make a low approach along the runway at 500 FT above the terrain, rocking wings of the aircraft until it reaches end of the runway.
- Re-enter downwind leg and observe light signals from the control tower.

4.2.2.2 Night time

- Joining the traffic pattern of the landing runway be conformed to the altitude for the type of aircraft as listed in item 3, then make a low approach along the runway at 500 FT above the terrain, and blinking the landing light until it reaches end of runway.
- Re-enter downwind leg and observe light signals from the control tower for light signal on base leg and final approach.

5. LOCAL FLYING RESTRICTION

Flying over gas separation plant in Rayong (Ban Map Ta Phut) is hazardous. Aircraft are to avoid area starting from 1241.2N 10108.0E then clockwise along an arc of 2 NM radius from 1243.0N 10109.0E to 1243.0N 10111.0E then direct to 1238.5N 10111.0E from this point make an arc of 5 NM radius from 1243.0N 10109.0E clockwise to 1238.2N 10108.0E then direct to the starting point, altitude 2 000 FT.

VTBU AD 2.21 NOISE ABATEMENT PROCEDURES

NIL

VTBU AD 2.22 FLIGHT PROCEDURES

1. GENERAL PROCEDURES

1.1 All aircraft flying within U-TAPAO Controlled airspaces equipped with SSR Transponder shall be provided Radar Approach Control Service, and other provided procedural.

1.2 Service Designation

1.2.1 Radar Approach Control Service

1.2.1.1 Aircraft to be provided by Radar Approach Control Service by means of SSR shall be equipped with a functioning operating on the appropriate MODE(S) and CODE (S)

1.2.1.2 The provision of Radar Approach Control Service:

- a) Provide Radar Vectoring of Arriving traffic on to pilot-Interpreted Final Approach Aids
- b) Provide Radar Vectoring of Arriving traffic to a point from which a Visual Approach can be complete
- c) Provide Radar Monitoring of other pilot-Interpreted Approaches.
- d) Provide Radar Monitoring of aircraft equipped with SSR transponder while in affected airspace.
- e) Provided Radar Separation between:
 - Succeeding Departing Aircraft.
 - Succeeding Arriving Aircraft.
 - A Departing aircraft and a Succeeding Arriving aircraft.

1.2.2 Procedural

Procedural shall be applied between Aircraft with functioning transponder and other aircraft, and between all non-transponding aircraft within the affected airspace.

1.3 All Aircraft shall obtain appropriate ATC Clearance before penetrating the affected airspace.

1.4 The radar separation Minimum to be used is 5 NM.

1.5 Emergency safe altitude for aircraft within 100 NM of U-Tapao Rayong Pattaya International Airport is 7,600 FT, descend below this level is only permitted in accordance with published Instrument Approach Procedures or ATS Routes Structure or Minimum Vector Altitude or Minimum Sector Altitude or when the aircraft having reported the terrain in-sight and has been cleared for visual approach.

1.6 Transition level is fixed at FL 130 and transition altitude is altitude 11,000 FT

1.7 Speed control may be applied on a tactical to the extent-determined necessary by the controller. Aircraft unable to conform to the speeds specified by the controller shall inform him immediately, and state what speeds will be used. In the interests of accurate spacing, pilot are requested to comply with speed adjustments as promptly as feasible within their own operational constraints, and should advise ATC if circumstance necessitate a change of speed for aircraft performance reasons.

VTBU AD 2.23 ADDITIONAL INFORMATION

NIL

VTBU AD 2.24 CHARTS RELATED TO AN AERODROME

Chart name	Page
Aerodrome Chart - ICAO	AD 2-VTBU-2-1
Aerodrome Ground Movement Chart - ICAO	AD 2-VTBU-2-3
Aerodrome Ground Movement Chart - ICAO (Verso)	AD 2-VTBU-2-4
Aerodrome Obstacle Chart - ICAO Type A - RWY 18/36	AD 2-VTBU-3-1
Standard Departure Chart - Instrument (SID) - ICAO - RNAV RWY 18 - BKK1A	AD 2-VTBU-6-1
Standard Departure Chart - Instrument (SID) - ICAO - RNAV RWY 18 - BKK1A (Tabular description)	AD 2-VTBU-6-2
Standard Departure Chart - Instrument (SID) - ICAO - RNAV RWY 36 - BKK1B	AD 2-VTBU-6-3
Standard Departure Chart - Instrument (SID) - ICAO - RNAV RWY 36 - BKK1B (Tabular description)	AD 2-VTBU-6-4
Instrument Approach Chart - ICAO - NDB RWY 36	AD 2-VTBU-8-1
Instrument Approach Chart - ICAO - VOR RWY 18	AD 2-VTBU-8-3
Instrument Approach Chart - ICAO - VOR RWY 18 (Fix and point list table)	AD 2-VTBU-8-4
Instrument Approach Chart - ICAO - VOR RWY 36	AD 2-VTBU-8-5

Chart name	Page
Instrument Approach Chart - ICAO - VOR RWY 36 (Fix and point list table)	AD 2-VTBU-8-6
Instrument Approach Chart - ICAO - ILS or LOC RWY 18	AD 2-VTBU-8-7
Instrument Approach Chart - ICAO - ILS or LOC RWY 18 (Fix and point list table)	AD 2-VTBU-8-8
Instrument Approach Chart - ICAO - RNP RWY 18	AD 2-VTBU-8-9
Instrument Approach Chart - ICAO - RNP RWY 18 (Tabular description)	AD 2-VTBU-8-10
Instrument Approach Chart - ICAO - RNP RWY 36	AD 2-VTBU-8-11
Instrument Approach Chart - ICAO - RNP RWY 36 (Tabular description)	AD 2-VTBU-8-12

INTENTIONALLY BLANK

AERODROME CHART - ICAO 12 40 46.6 N ELEV 59 ft TWR 118.3 GND 121.9 RAYONG / U-TAPHAO INTL AIRPORT

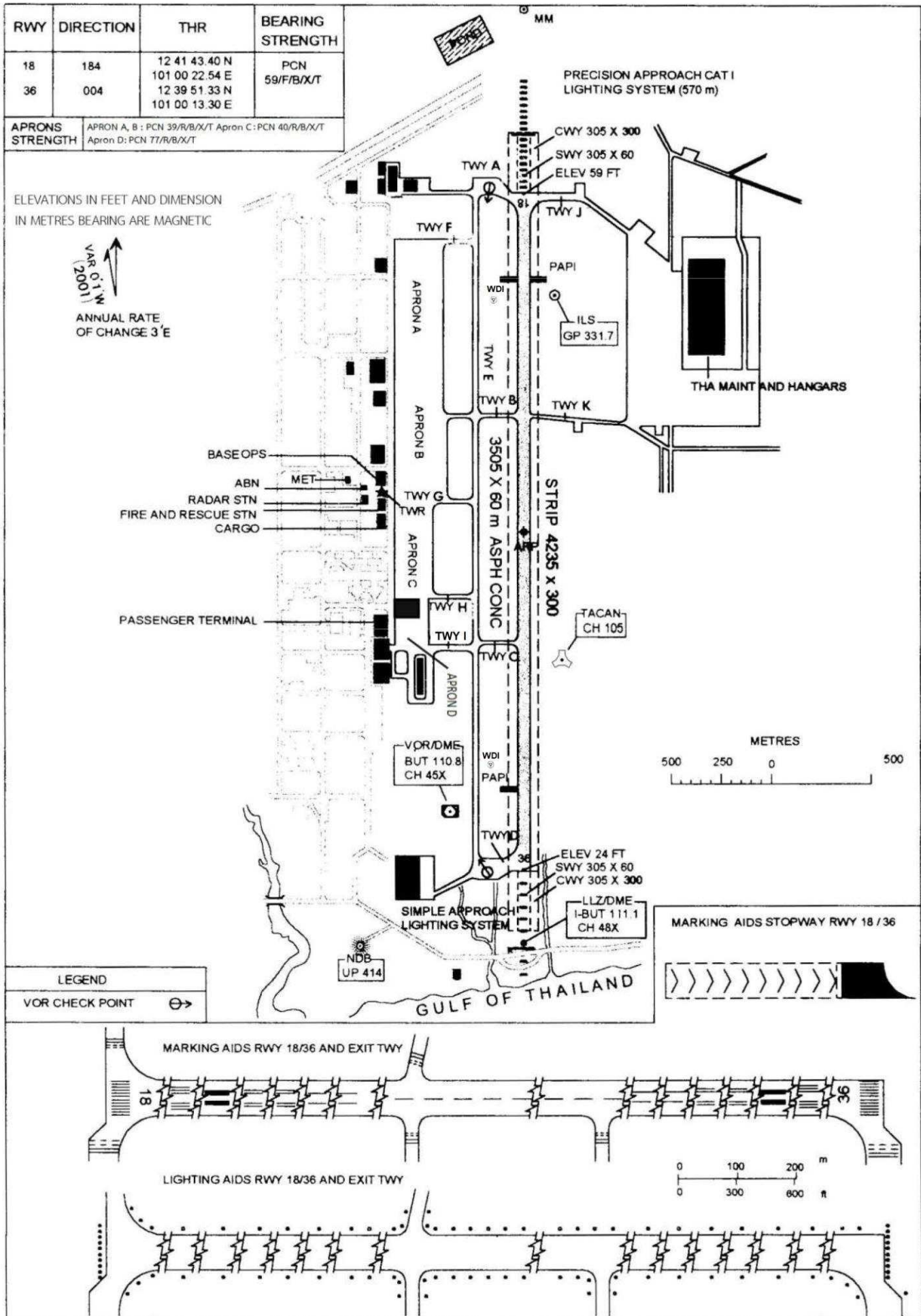

INTENTIONALLY BLANK

AERODROME GROUND MOVEMENT CHART

Rayong / U-Taphao International Airport

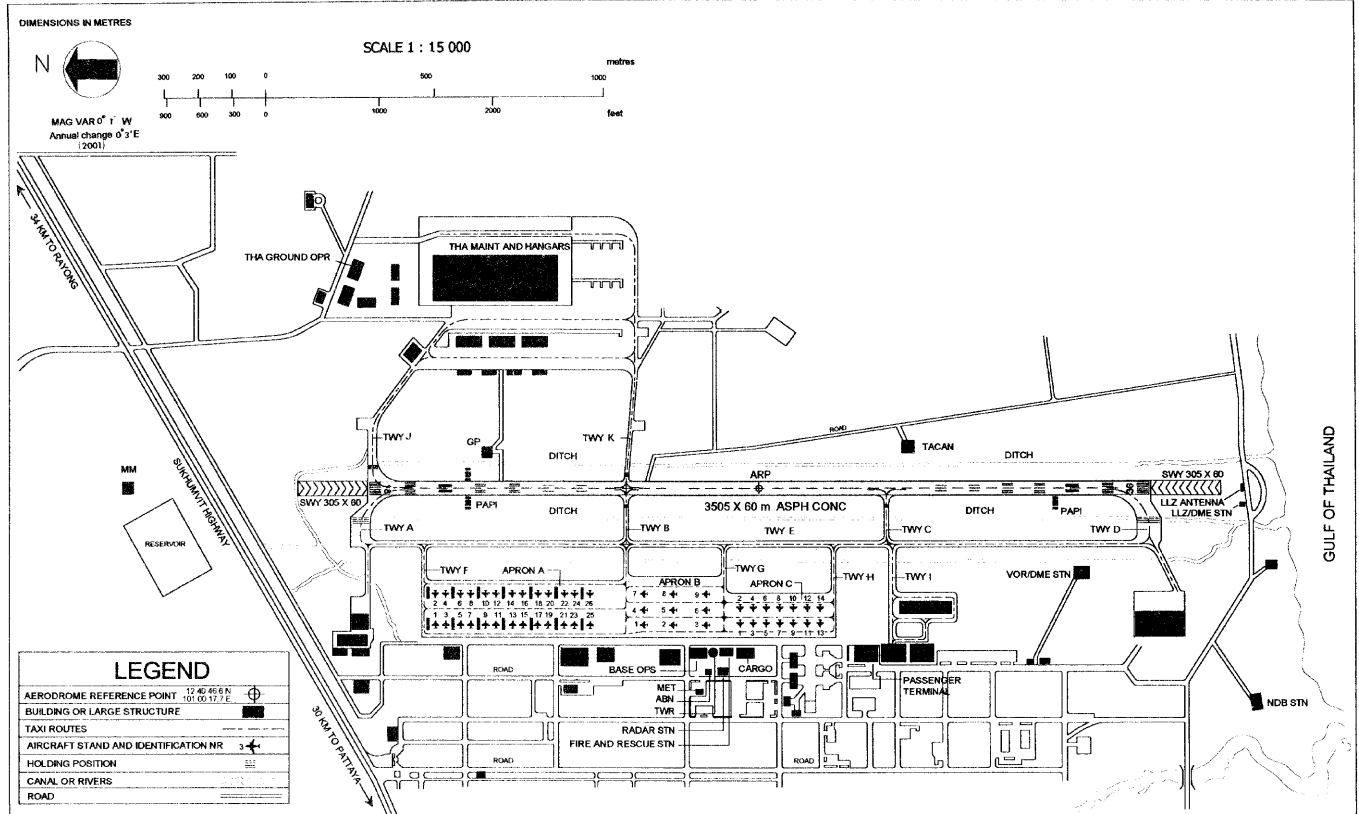

APRON A (B747-400)

APRON B (B747-400)

APRON C (B747-400)

NR	COORDINATES	NR	COORDINATES	NR	COORDINATES	NR	COORDINATES
A1	12 41 34.01 N 101 00 02.38 E	A14	12 41 21.75 N 101 00 04.41 E	B1	12 41 05.77 N 100 59 58.91 E	C1	12 40 52.07 N 100 59 58.85 E
A2	12 41 33.58 N 101 00 05.90 E	A15	12 41 20.20 N 101 00 01.79 E	B2	12 41 00.82 N 100 59 58.50 E	C2	12 40 52.12 N 101 00 02.59 E
A3	12 41 32.13 N 101 00 02.23 E	A16	12 41 19.79 N 101 00 04.25 E	B3	12 40 56.88 N 100 59 58.16 E	C3	12 40 50.10 N 100 59 58.68 E
A4	12 41 31.80 N 101 00 05.73 E	A17	12 41 18.21 N 101 00 01.58 E	B4	12 41 05.58 N 101 00 01.17 E	C4	12 40 50.24 N 101 00 02.44 E
A5	12 41 30.08 N 101 00 02.60 E	A18	12 41 17.81 N 101 00 04.59 E	B5	12 41 00.64 N 101 00 00.78 E	C5	12 40 48.22 N 100 59 58.52 E
A6	12 41 29.82 N 101 00 05.56 E	A19	12 41 16.30 N 101 00 00.91 E	B6	12 40 56.69 N 101 00 00.44 E	C6	12 40 48.26 N 101 00 02.28 E
A7	12 41 28.14 N 101 00 02.39 E	A20	12 41 15.77 N 101 00 04.42 E	B7	12 41 05.40 N 101 00 03.44 E	C7	12 40 46.24 N 100 59 58.36 E
A8	12 41 27.69 N 101 00 05.01 E	A21	12 41 14.30 N 101 00 01.14 E	B8	12 41 00.47 N 101 00 03.05 E	C8	12 40 46.28 N 101 00 02.12 E
A9	12 41 26.22 N 101 00 01.74 E	A22	12 41 13.80 N 101 00 04.26 E	B9	12 40 56.50 N 101 00 02.70 E	C9	12 40 44.26 N 100 59 58.19 E
A10	12 41 25.81 N 101 00 04.69 E	A23	12 41 12.28 N 101 00 01.08 E			C10	12 40 44.31 N 101 00 01.95 E
A11	12 41 24.22 N 101 00 01.57 E	A24	12 41 11.86 N 101 00 04.10 E			C11	12 40 42.28 N 100 59 58.03 E
A12	12 41 23.73 N 101 00 04.48 E	A25	12 41 10.33 N 101 00 00.42 E			C12	12 40 42.32 N 101 00 01.79 E
A13	12 41 22.10 N 101 00 01.95 E	A26	12 41 09.87 N 101 00 03.93 E			C13	12 40 40.21 N 100 59 57.87 E
						C14	12 40 40.34 N 101 00 01.62 E

AERODROME OBSTRUCTION CHART - ICAO

TYPE A - OPERATION LIMITATIONS

RAYONG/U-Tapao International Airport

DIMENSIONS AND ELEVATIONS IN METERS
MAGNETIC VARIATION 0° 1' W (2001)

OPERATIONAL DATA			
RWY 18		RWY 36	
3 505	TAKE - OFF RUN AVAILABLE	3 505	
3 810	TAKE - OFF DISTANCE AVAILABLE	3 810	
3 810	ACCELERATE STOP DISTANCE AVAILABLE	3 810	
3 505	LANDING DISTANCE AVAILABLE	3 505	

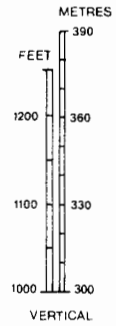
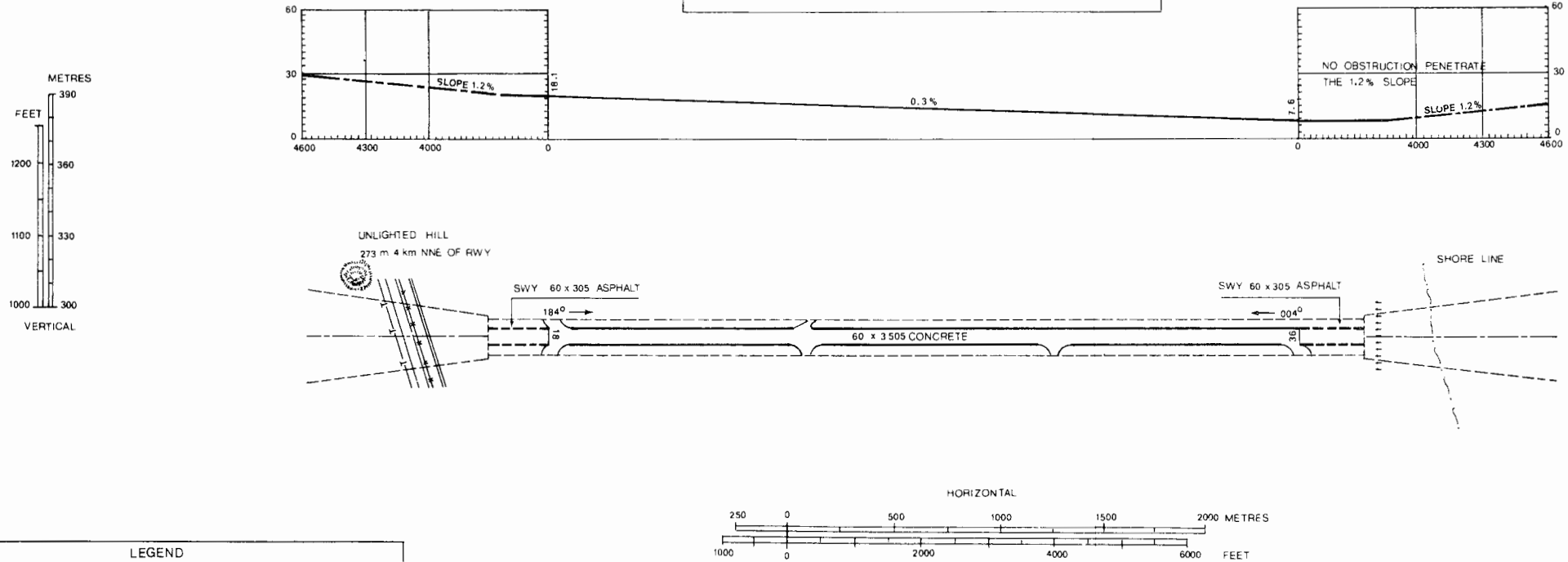

LEGEND	
BOUNDARY FENCE	—•••••
HIGH WAY	====
HIGH TENSION LINE	—T—T—

INTENTIONALLY BLANK

**STANDARD DEPARTURE CHART-
INSTRUMENT (SID) - ICAO**

TRANSITION ALTITUDE
11000 FT

SPEED RESTRICTION
MAX IAS 250 KT AT OR
BELOW ALT 10000 FT
UNLESS OTHERWISE
AUTHORIZED BY ATC.

APP : 119.7, 134.5
: 238.3, 273.3
TWR : 118.1, 118.3
: 227.0
GND : 121.9, 275.8

**RAYONG / U-TAPAO RAYONG
PATTAYA Int'l (VTBU)
RNAV RWY18**

BKK1A

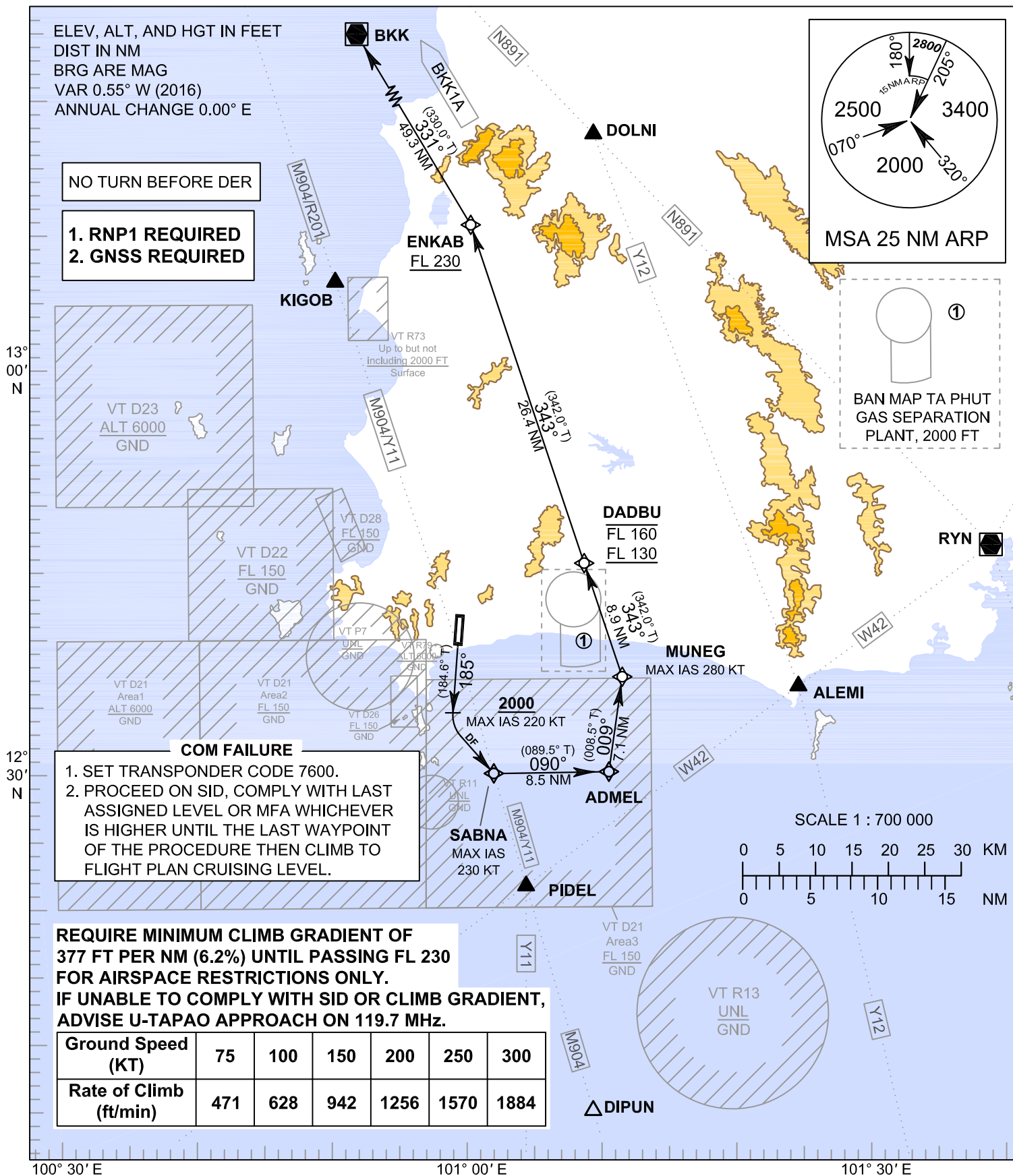

STANDARD DEPARTURE CHART-
INSTRUMENT (SID) - ICAO

RAYONG / U-TAPAO RAYONG
PATTAYA Intl (VTBU)
RNAV RWY18

BKK1A

TABULAR DESCRIPTION

RNAV RWY18											
Serial Number	Path Descriptor	Waypoint Identifier	Flyover	Course ° M (° T)	Magnetic Variation	Distance (NM)	Turn Direction	Altitude (FT)	Speed (KT)	VPA/TCH	Navigation Specification
BKK1A											
010	-	DER RWY18	-	-	+0.55	-	-	-	-	-	RNP 1
020	CA	-	-	185°(184.6°)	+0.55	-	-	+2000	-220	-	RNP 1
030	DF	SABNA	-	-	+0.55	-	L	-	-230	-	RNP 1
040	TF	ADMEL	-	090°(089.5°)	+0.55	8.5	L	-	-	-	RNP 1
050	TF	MUNEG	-	009°(008.5°)	+0.55	7.1	L	-	-280	-	RNP 1
060	TF	DADBU	-	343°(342.0°)	+0.55	8.9	-	-FL160 ; +FL130	-	-	RNP 1
070	TF	ENKAB	-	343°(342.0°)	+0.55	26.4	L	+FL230	-	-	RNP 1
080	TF	BKK	-	331°(330.0°)	+0.55	49.3	-	-	-	-	RNP 1

WAYPOINT LIST

RNAV RWY18	
Waypoint Identifier	Coordinates
DER RWY18	12° 39' 50.42" N 101° 00' 13.26" E
ADMEL	12° 30' 09.67" N 101° 11' 34.85" E
BKK	13° 53' 36.80" N 100° 35' 46.30" E
DADBU	12° 45' 41.72" N 101° 09' 50.05" E
ENKAB	13° 10' 57.00" N 101° 01' 26.00" E
MUNEG	12° 37' 12.93" N 101° 12' 38.89" E
SABNA	12° 30' 04.87" N 101° 02' 51.33" E

**STANDARD DEPARTURE CHART-
INSTRUMENT (SID) - ICAO**

TRANSITION ALTITUDE
11000 FT

SPEED RESTRICTION
MAX IAS 250 KT AT OR
BELOW ALT 10000 FT
UNLESS OTHERWISE
AUTHORIZED BY ATC.

APP : 119.7, 134.5
: 238.3, 273.3
TWR : 118.1, 118.3
: 227.0
GND : 121.9, 275.8

**RAYONG / U-TAPAO RAYONG
PATTAYA Intl (VTBU)
RNAV RWY36**

BKK1B

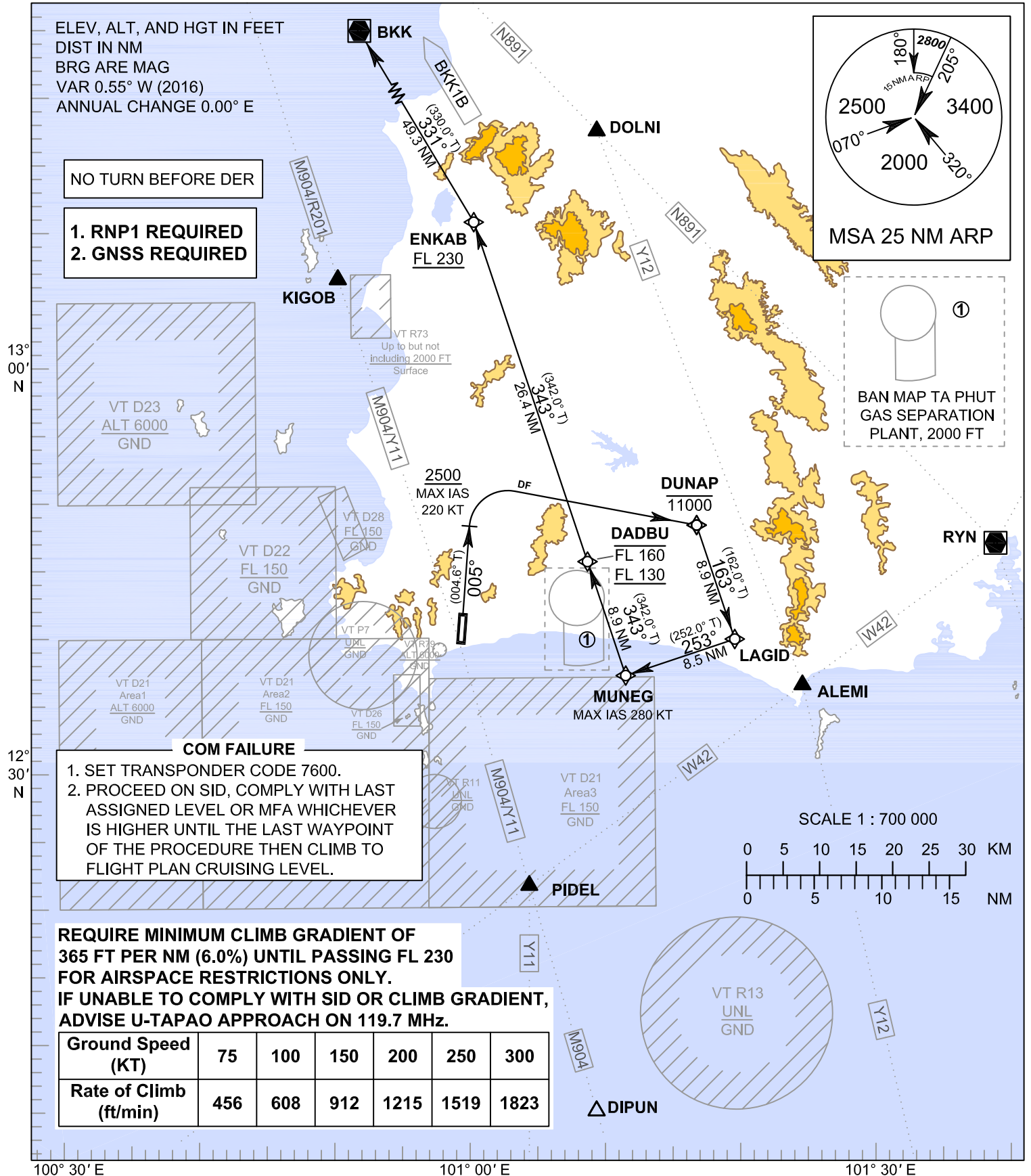

STANDARD DEPARTURE CHART-
INSTRUMENT (SID) - ICAO

RAYONG / U-TAPAO RAYONG
PATTAYA Intl (VTBU)
RNAV RWY36

BKK1B

TABULAR DESCRIPTION

RNAV RWY36											
Serial Number	Path Descriptor	Waypoint Identifier	Flyover	Course ° M (° T)	Magnetic Variation	Distance (NM)	Turn Direction	Altitude (FT)	Speed (KT)	VPA/TCH	Navigation Specification
BKK1B											
010	-	DER RWY36	-	-	+0.55	-	-	-	-	-	RNP 1
020	CA	-	-	005°(004.6°)	+0.55	-	-	+2500	-220	-	RNP 1
030	DF	DUNAP	-	-	+0.55	-	R	-11000	-	-	RNP 1
040	TF	LAGID	-	163°(162.0°)	+0.55	8.9	R	-	-	-	RNP 1
050	TF	MUNEG	-	253°(252.0°)	+0.55	8.5	R	-	-280	-	RNP 1
060	TF	DADBU	-	343°(342.0°)	+0.55	8.9	-	-FL160 ; +FL130	-	-	RNP 1
070	TF	ENKAB	-	343°(342.0°)	+0.55	26.4	L	+FL230	-	-	RNP 1
080	TF	BKK	-	331°(330.0°)	+0.55	49.3	-	-	-	-	RNP 1

WAYPOINT LIST

RNAV RWY36	
Waypoint Identifier	Coordinates
DER RWY36	12° 41' 44.26" N 101° 00' 22.66" E
BKK	13° 53' 36.80" N 100° 35' 46.30" E
DADBU	12° 45' 41.72" N 101° 09' 50.05" E
DUNAP	12° 48' 20.33" N 101° 18' 06.34" E
ENKAB	13° 10' 57.00" N 101° 01' 26.00" E
LAGID	12° 39' 51.46" N 101° 20' 54.94" E
MUNEG	12° 37' 12.93" N 101° 12' 38.89" E

INSTRUMENT APPROACH CHART-ICAO AERODROME ELEV 59 ft
HEIGHTS RELATED TO THR RWY 36 ELEV 24 ft APP 119.7,273.3 RAYONG / U-Taphao INTL
TWR 118.3,227.0 NDB
RWY 36

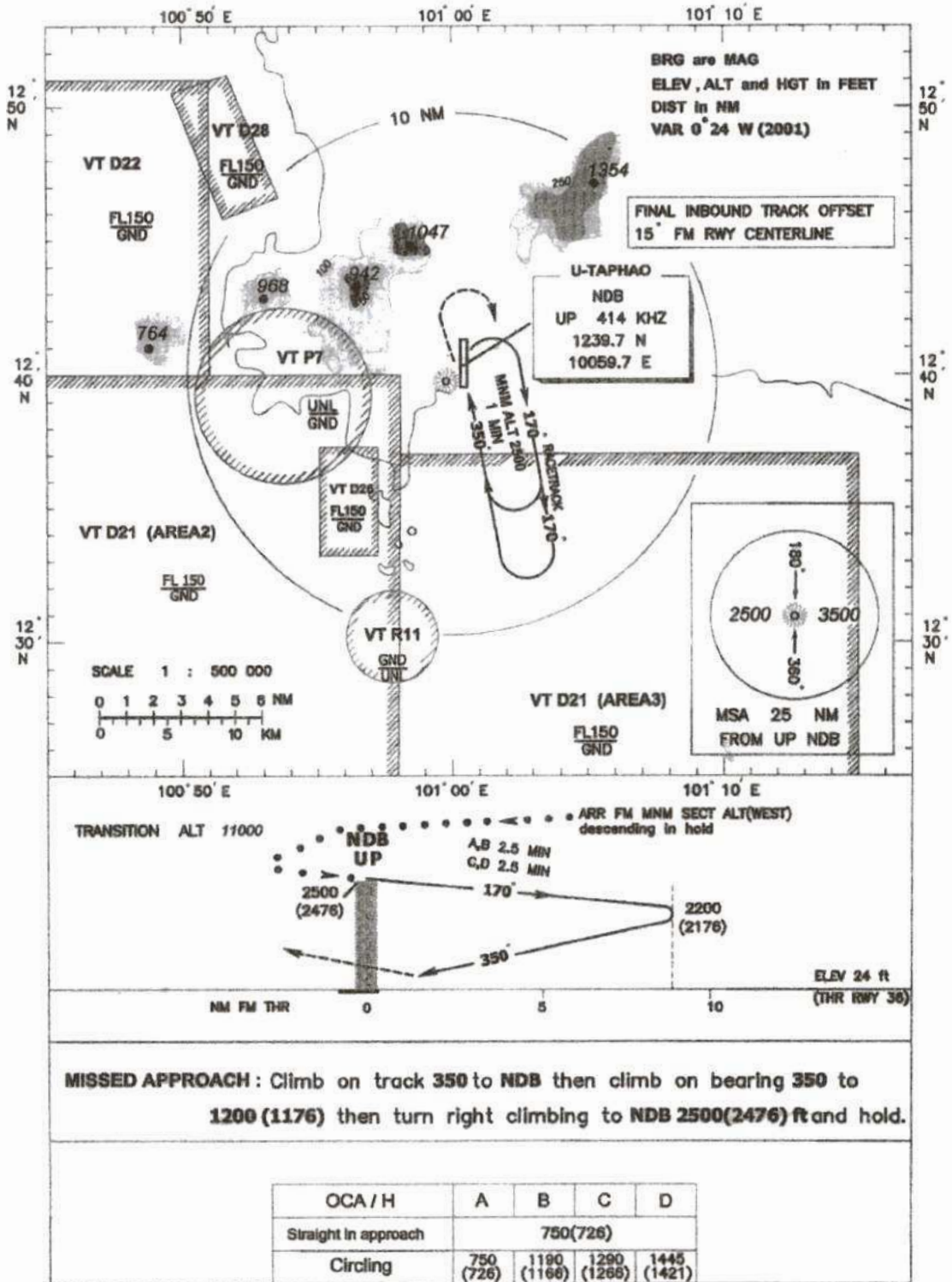

INTENTIONALLY BLANK

**INSTRUMENT
APPROACH
CHART - ICAO**

**AERODROME ELEV 59 FT
HEIGHTS RELATED TO
AERODROME ELEV**

APP : 119.7 , 134.5
: 238.3 , 273.3
TWR : 118.1 , 118.3
: 227.0
GND : 121.9 , 275.8

**RAYONG / U-TAPAO RAYONG
PATTAYA INTL (VTBU)**

VOR RWY18

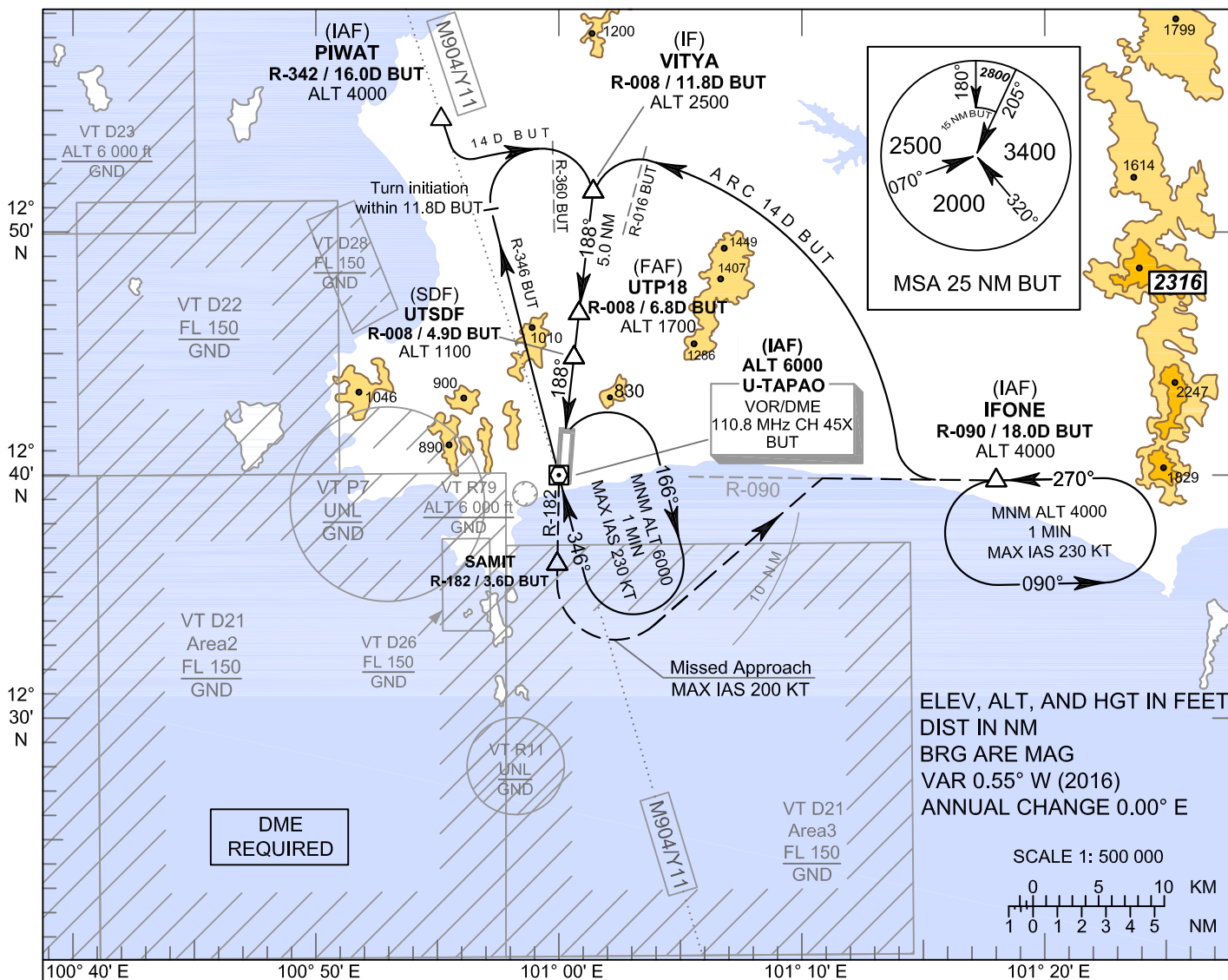

CAUTION: Aircraft shall avoid entering VT R11

MISSED APPROACH:
No turn before MAPt.
Speed restricted to **MAX IAS 200 KT** until after turn.
Climb to intercept outbound R-182 BUT VOR to SAMIT. After SAMIT and ALT passing 1500 FT, turn left to intercept outbound R-090 BUT VOR, then proceed to IFONE and hold or as directed by ATC

	SAMIT	VOR/DME BUT (MAPt)	(SDF) UTSDF	(FAF) UTP18	(IF) VITYA						
DME FM VOR/DME	3.6	0	4.5	4.9	11.8						
NM FM THR		0	2.7	3.1	10.0						
OCA/H	A	B	C	D	Distance (BUT)	4.5 D	5 D	6 D	FAF		
Straight-in Approach	960 (901)				Altitude (Height)	960 (901)	1120 (1061)	1435 (1376)	1700 (1641)		
					Ground speed	knot	70	90	100	120	140
Circling (OCH AAL)	1200 (1141)		1450 (1391)		Rate of descent (ft/min)	369	474	527	632	737	843

**INSTRUMENT
APPROACH
CHART - ICAO**

**AERODROME ELEV 59 FT
HEIGHTS RELATED TO
AERODROME ELEV**

**RAYONG / U-TAPAO RAYONG
PATTAYA INTL (VTBU)**

VOR RWY18

Fix / Point		Coordinates	
PIWAT (IAF)	R-342 / 16.0D BUT	12 55 16.58 N	100 54 56.50 E
VITYA (IF)	R-008 / 11.8D BUT	12 51 42.99 N	101 01 30.24 E
UTP18 (FAF)	R-008 / 6.8D BUT	12 46 43.34 N	101 00 52.49 E
UTSDF (SDF)	R-008 / 4.9D BUT	12 44 49.70 N	101 00 38.17 E
MAPt	1.8D BUT	12 41 45.04 N	101 00 14.93 E
THR RWY18	-	12 41 44.26 N	101 00 22.66 E
VOR (IAF)	BUT	12 40 00.02 N	101 00 01.71 E
SAMIT	R-182 / 3.6D BUT	12 36 20.17 N	100 59 55.90 E
IFONE (IAF)	R-090 / 18.0D BUT	12 40 11.24 N	101 18 26.44 E

**INSTRUMENT
APPROACH
CHART - ICAO**

**AERODROME ELEV 59 FT
HEIGHTS RELATED TO
THR RWY36 - ELEV 24 FT**

APP : 119.7 , 134.5
: 238.3 , 273.3
TWR : 118.1 , 118.3
: 227.0
GND : 121.9 , 275.8

**RAYONG / U-TAPAO RAYONG
PATTAYA INTL (VTBU)**

VOR RWY36

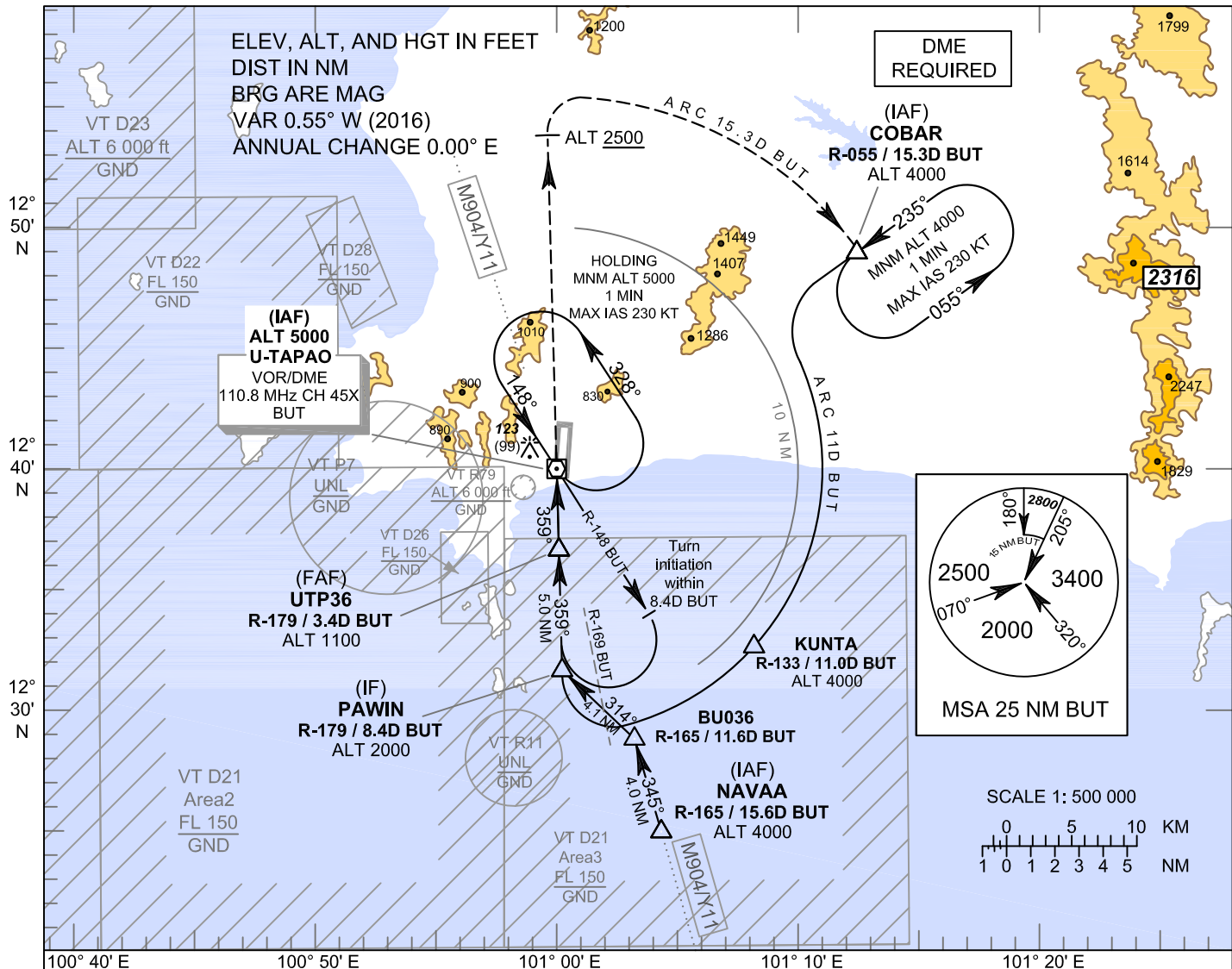

CAUTION: Aircraft shall avoid entering VT R11

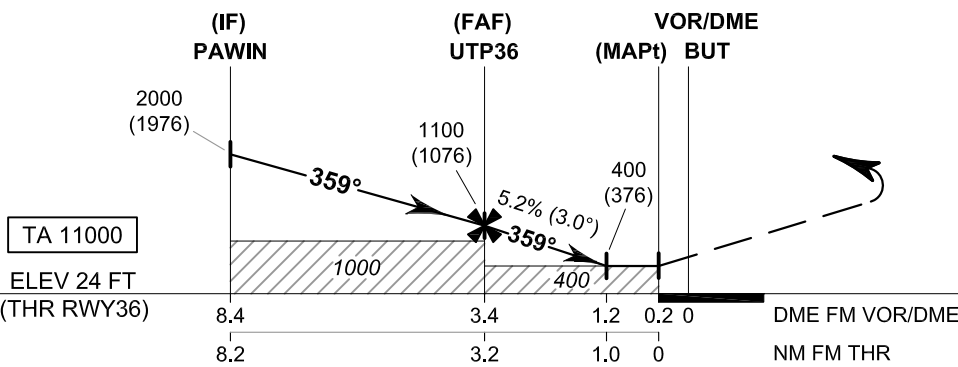

MISSED APPROACH:
No turn before MAPt.
Climb to COBAR at 4000 FT via
ARC 15.3 D BUT VOR
and hold or as directed by ATC
(ALT at least 2500 FT before
follow ARC).

OCA/H	A	B	C	D	Distance (BUT)	FAF	3 D	2 D	1.2 D		
Straight-in Approach	400 (376)				Altitude (Height)	1100 (1076)	960 (936)	645 (621)	400 (376)		
					Ground speed	knot 70	90	100	120	140	160
Circling (OCH AAL)	1200 (1141)		1450 (1391)		Rate of descent (ft/min)	369	474	527	632	737	843

**INSTRUMENT
APPROACH
CHART - ICAO**

**AERODROME ELEV 59 FT
HEIGHTS RELATED TO
THR RWY36 - ELEV 24 FT**

**RAYONG / U-TAPAO RAYONG
PATTAYA INTL (VTBU)**

VOR RWY36

Fix / Point		Coordinates	
NAVAA (IAF)	R-165 / 15.6D BUT	12 24 52.49 N	101 04 20.27 E
BU036	R-165 / 11.6D BUT	12 28 44.64 N	101 03 14.18 E
PAWIN (IF)	R-179 / 8.4D BUT	12 31 37.12 N	101 00 11.72 E
UTP36 (FAF)	R-179 / 3.4D BUT	12 36 37.94 N	101 00 05.73 E
MAPt	0.2D BUT	12 39 50.76 N	101 00 01.89 E
THR RWY36	-	12 39 50.42 N	101 00 13.26 E
VOR (IAF)	BUT	12 40 00.02 N	101 00 01.71 E
COBAR (IAF)	R-055 / 15.3D BUT	12 48 53.69 N	101 12 49.13 E
KUNTA	R-133 / 11.0D BUT	12 32 33.09 N	101 08 20.24 E

**INSTRUMENT
APPROACH
CHART - ICAO**

**AERODROME ELEV 59 FT
HEIGHTS RELATED TO
THR RWY18 - ELEV 59 FT**

APP : 119.7 , 134.5
: 238.3 , 273.3
TWR : 118.1 , 118.3
: 227.0
GND : 121.9 , 275.8

**RAYONG / U-TAPAO RAYONG
PATTAYA INTL (VTBU)**

ILS or LOC RWY18

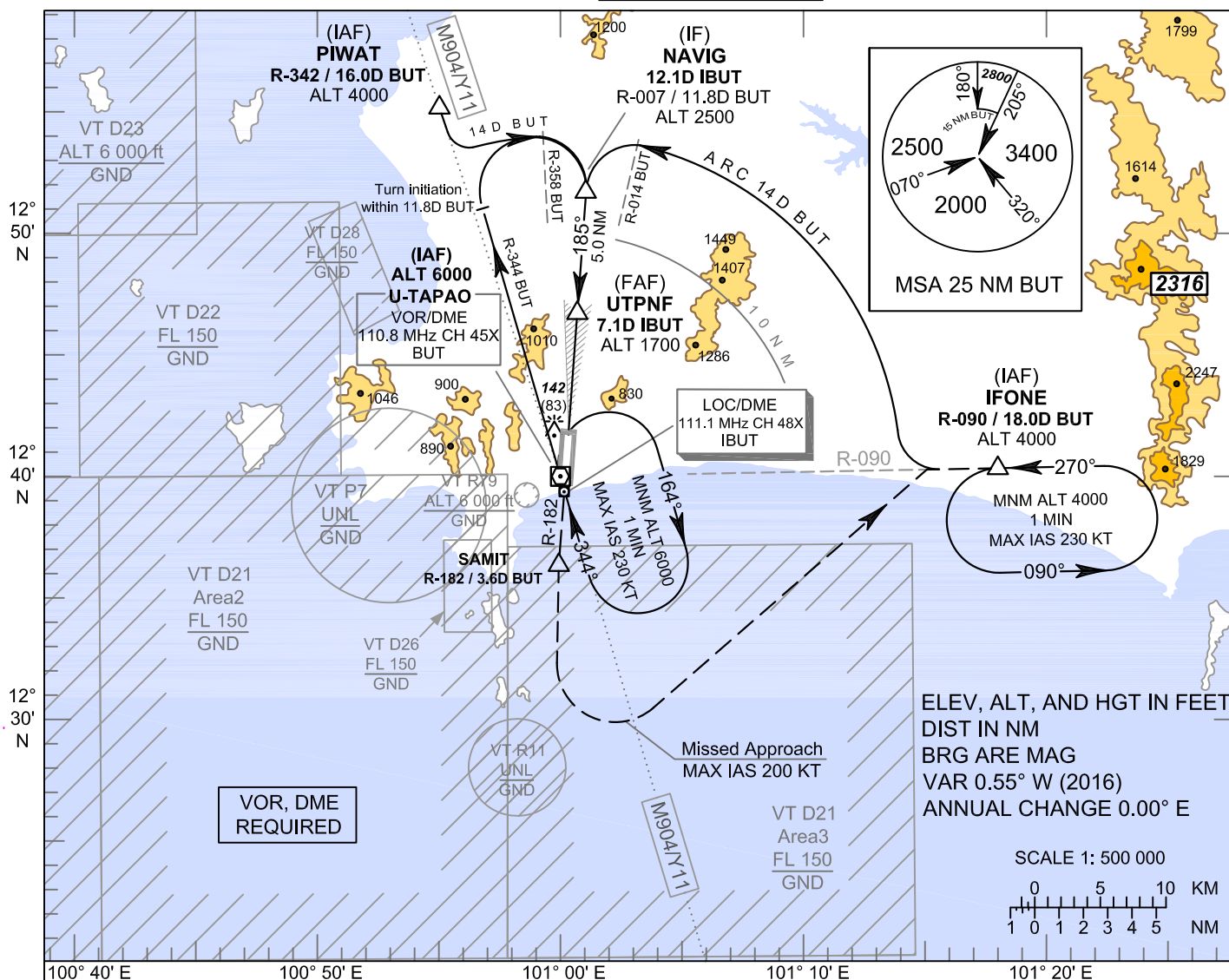

CAUTION: Aircraft shall avoid entering VT R11

MISSED APPROACH:
No turn before MAPt.
Speed restricted to
MAX IAS 200 KT until after turn.
Climb to intercept outbound R-182 BUT
VOR to SAMIT. After SAMIT and ALT
passing 1500 FT, turn left to intercept
outbound R-090 BUT VOR, then
proceed to IFONE and hold
or as directed by ATC.

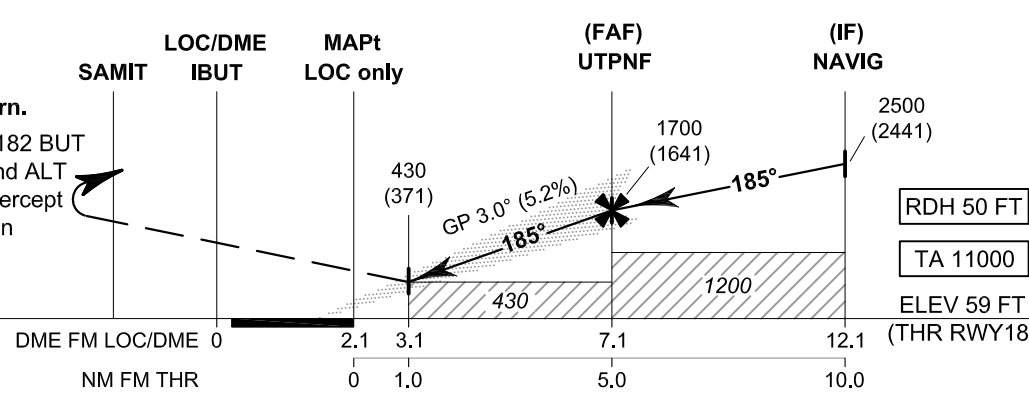

OCA/H	A	B	C	D	GS OUT	Distance (IBUT)	3.1 D	4 D	5 D	6 D	FAF		
Straight - in Approach	CAT I					Altitude (Height)	430 (371)	710 (651)	1025 (966)	1340 (1281)	1700 (1641)		
LOC only						Ground speed	knot	70	90	100	120	140	160
Circling (OCH AAL)	1200 (1141)	1450 (1391)				Rate of descent (5.2%)	(ft/min)	369	474	527	632	737	843

**INSTRUMENT
APPROACH
CHART - ICAO**

**AERODROME ELEV 59 FT
HEIGHTS RELATED TO
THR RWY18 - ELEV 59 FT**

**RAYONG / U-TAPAO RAYONG
PATTAYA INTL (VTBU)**

ILS or LOC RWY18

Fix / Point		Coordinates	
PIWAT (IAF)	R-342 / 16.0D BUT	12 55 16.58 N	100 54 56.50 E
NAVIG (IF)	12.1D IBUT	12 51 44.95 N	101 01 12.29 E
UTPNF (FAF)	7.1D IBUT	12 46 44.61 N	101 00 47.47 E
MAPt (LOC only)	2.1D IBUT	12 41 44.26 N	101 00 22.66 E
LOC / DME	IBUT	12 39 36.66 N	101 00 12.13 E
VOR (IAF)	BUT	12 40 00.02 N	101 00 01.71 E
SAMIT	R-182 / 3.6D BUT	12 36 20.17 N	100 59 55.90 E
IFONE (IAF)	R-090 / 18.0D BUT	12 40 11.24 N	101 18 26.44 E

**INSTRUMENT
APPROACH
CHART - ICAO**

**AERODROME ELEV 59 FT
HEIGHTS RELATED TO
AERODROME ELEV**

APP : 119.7 , 134.5
: 238.3 , 273.3
TWR : 118.1 , 118.3
: 227.0
GND : 121.9 , 275.8

**RAYONG / U-TAPAO RAYONG
PATTAYA INTL (VTBU)**

RNP RWY18

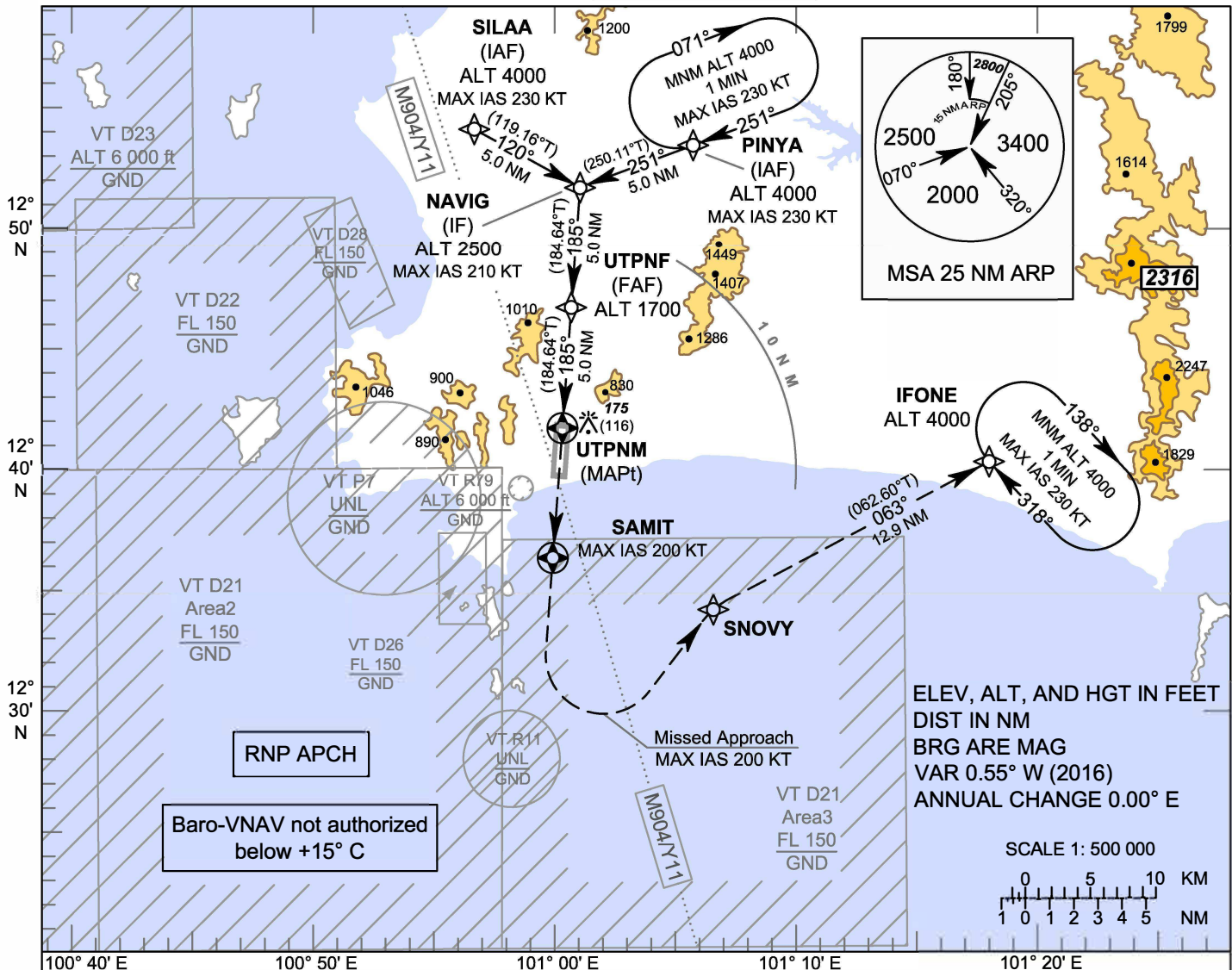

CAUTION: Aircraft shall avoid entering VT R11

MISSED APPROACH:
No turn before MAPt.
Speed restricted to MAX IAS 200 KT until after turn.
Climb on course 185° to SAMIT.
After SAMIT and ALT passing 1500 FT, turn left direct to SNOVY, then proceed to IFONE at 4000 FT, and hold or as directed by ATC.

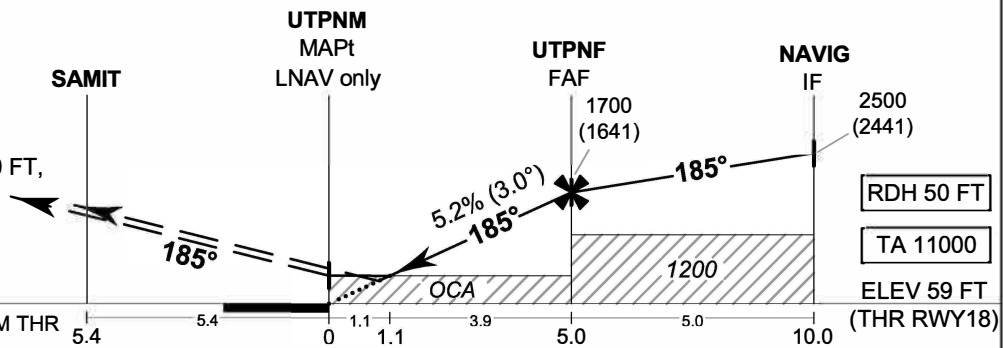

CHANGE: CHART TITLE:

OCA/H	A	B	C	D	NM to NEXT WPT	1.1 NM	2 NM	3 NM	4 NM	FAF		
LNAV / VNAV	400 (341)				Altitude (Height)	460 (401)	740 (681)	1055 (996)	1375 (1316)	1700 (1641)		
LNAV	460 (401)				Ground speed	knot	70	90	100	120	140	160
Circling (OCH AAL)	1200 (1141)	1450 (1391)			Rate of descent FAF-MAPt 5.2%	(ft/min)	369	474	527	632	737	843

**INSTRUMENT
APPROACH
CHART - ICAO**

**AERODROME ELEV 59 FT
HEIGHTS RELATED TO
AERODROME ELEV**

**RAYONG / U-TAPAO RAYONG
PATTAYA INTL (VTBU)**

RNP RWY18

TABULAR DESCRIPTION

RNP RWY18											
Serial	Path	Waypoint Identifier	Flyover	Course	Magnetic	Distance	Turn	Altitude	Speed	VPA/	Navigation
Number	Descriptor			° M (° T)	Variation	(NM)	Direction	(FT)	(KT)	TCH	Specification
010	IF	SILAA (IAF)	-	-	+0.55	-	-	@4000	-230	-	RNP APCH
020	TF	NAVIG (IF)	-	120°(119.16°)	+0.55	5.0	-	@2500	-210	-	RNP APCH
010	IF	PINYA (IAF)	-	-	+0.55	-	-	@4000	-230	-	RNP APCH
020	TF	NAVIG (IF)	-	251°(250.11°)	+0.55	5.0	-	@2500	-210	-	RNP APCH
010	IF	NAVIG (IF)	-	-	+0.55	-	-	@2500	-210	-	RNP APCH
020	TF	UTPNF (FAF)	-	185°(184.64°)	+0.55	5.0	-	@1700	-	-	RNP APCH
030	TF	UTPNM (MAPt)	Y	185°(184.64°)	+0.55	5.0	-	@109	-	-3.0/50	RNP APCH
040	CF	SAMIT	Y	185°(184.64°)	+0.55	5.4	-	-	-200	-	RNP APCH
050	FA	-	-	185°(184.64°)	+0.55	-	-	+1500	-200	-	RNP APCH
060	DF	SNOVY	-	-	+0.55	-	L	-	-	-	RNP APCH
070	TF	IFONE	-	063°(062.60°)	+0.55	12.9	-	+4000	-	-	RNP APCH
080	HM	IFONE	Y	318°(317.38°)	+0.55	1 minute	R	+4000	-230	-	RNP APCH

WAYPOINT LIST

RNP RWY18	
Waypoint Identifier	Coordinates
SILAA	12° 54' 11.47" N 100° 56' 44.52" E
PINYA	12° 53' 27.22" N 101° 06' 00.62" E
NAVIG	12° 51' 44.95" N 101° 01' 12.29" E
UTPNF	12° 46' 44.61" N 101° 00' 47.47" E
UTPNM (THR18)	12° 41' 44.26" N 101° 00' 22.66" E
SAMIT	12° 36' 20.17" N 100° 59' 55.90" E
SNOVY	12° 34' 12.28" N 101° 06' 41.89" E
IFONE	12° 40' 11.24" N 101° 18' 26.44" E

CHANGE: CHART TITLE.

**INSTRUMENT
APPROACH
CHART - ICAO**

**AERODROME ELEV 59 FT
HEIGHTS RELATED TO
THR RWY36 - ELEV 24 FT**

APP : 119.7 , 134.5
: 238.3 , 273.3
TWR : 118.1 , 118.3
: 227.0
GND : 121.9 , 275.8

**RAYONG / U-TAPAO RAYONG
PATTAYA INTL (VTBU)**

RNP RWY36

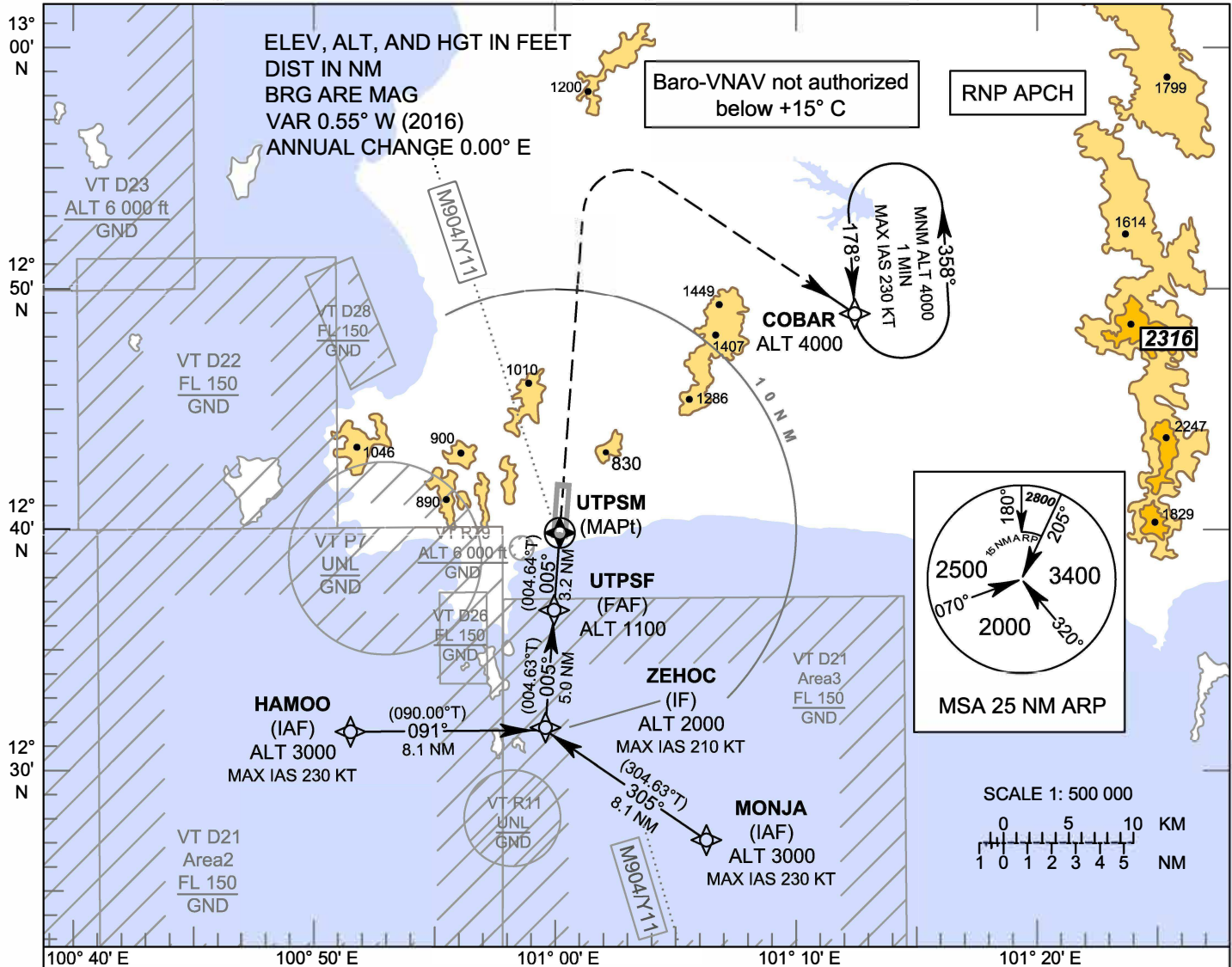

CAUTION: Aircraft shall avoid entering VT R11

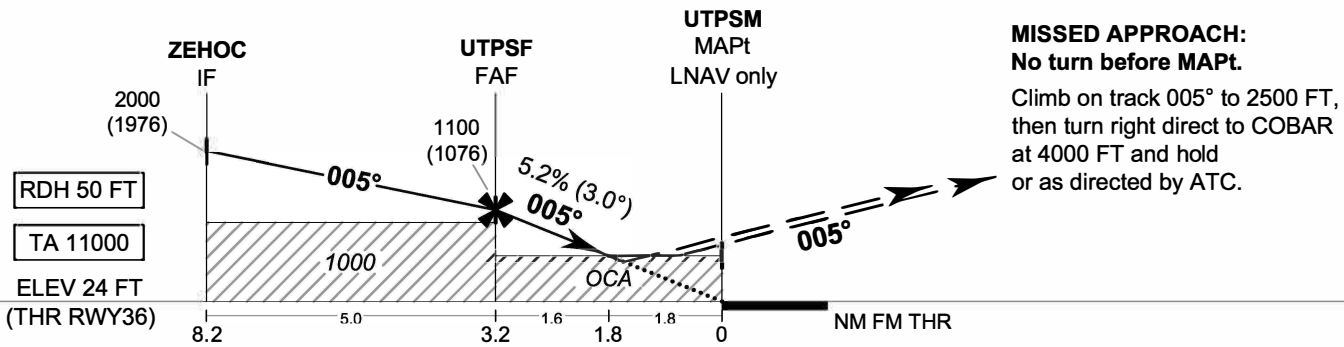

CHANGE: CHART TITLE:

OCA/H	A	B	C	D	NM to NEXT WPT	FAF	3 NM	2 NM	1.5 NM			
LNAV / VNAV	480 (456)				Altitude (Height)	1100 (1076)	1020 (996)	705 (681)	560 (536)			
LNAV	640 (616)				Ground speed	knot	70	90	100	120	140	160
Circling (OCH AAL)	1200 (1141)		1450 (1391)		Rate of descent FAF-MAPt 5.2%	(ft/min)	369	474	527	632	737	843

**INSTRUMENT
APPROACH
CHART - ICAO**

**AERODROME ELEV 59 FT
HEIGHTS RELATED TO
THR RWY36 - ELEV 24 FT**

**RAYONG / U-TAPAO RAYONG
PATTAYA INTL (VTBU)**

RNP RWY36

TABULAR DESCRIPTION

RNP RWY36											
Serial	Path	Waypoint Identifier	Flyover	Course	Magnetic	Distance	Turn	Altitude	Speed	VPA/	Navigation
Number	Descriptor			° M (° T)	Variation	(NM)	Direction	(FT)	(KT)	TCH	Specification
010	IF	HAMOO (IAF)	-	-	+0.55	-	-	@3000	-230	-	RNP APCH
020	TF	ZEHOC (IF)	-	091°(090.00°)	+0.55	8.1	-	@2000	-210	-	RNP APCH
010	IF	MONJA (IAF)	-	-	+0.55	-	-	@3000	-230	-	RNP APCH
020	TF	ZEHOC (IF)	-	305°(304.63°)	+0.55	8.1	-	@2000	-210	-	RNP APCH
010	IF	ZEHOC (IF)	-	-	+0.55	-	-	@2000	-210	-	RNP APCH
020	TF	UTPSF (FAF)	-	005°(004.63°)	+0.55	5.0	-	@1100	-	-	RNP APCH
030	TF	UTPSM (MAPt)	Y	005°(004.64°)	+0.55	3.2	-	@74	-	-3.0/50	RNP APCH
050	CA	-	-	005°(004.64°)	+0.55	-	-	+2500	-	-	RNP APCH
060	DF	COBAR	-	-	+0.55	-	R	+4000	-	-	RNP APCH
080	HM	COBAR	Y	178°(176.97°)	+0.55	1 minute	L	+4000	-230	-	RNP APCH

WAYPOINT LIST

RNP RWY36	
Waypoint Identifier	Coordinates
HAMOO	12° 31' 37.71" N 100° 51' 16.77" E
MONJA	12° 27' 00.89" N 101° 06' 20.46" E
ZEHOC	12° 31' 37.84" N 100° 59' 32.61" E
UTPSF	12° 36' 38.20" N 100° 59' 57.39" E
UTPSM (THR36)	12° 39' 50.42" N 101° 00' 13.26" E
COBAR	12° 48' 53.69" N 101° 12' 49.13" E

CHANGE: CHART TITLE.